

小型φ20、高推力900 gで微小な位置決め(25 μm/1step)が可能

リニアステッピングアクチュエータ SPS20 STEPPING MOTORS

SPS20シリーズは、前部軸受けをネジ構造とすることにより回転力を直接推進力に変換できるアクチュエータです。シャフトは回転しながら繰り出しますので先端に鋼球が埋め込まれており、球の先で目標物を押す仕組みとなっております。モータ本体は普通のPM型ステッピングモータですので一般のステッピングモータドライバで駆動できます。また、特性は間欠駆動を前提としたものとなっております。連続で使用する場合の消費電力は1 W(放熱板無し)、5 W(B5判大1 mm厚鉄板取付)を目安としてください。

The SPS20 series uses a screw construction in the front shaft, creating an actuator for converting rotational force into linear force. The shaft extends as it rotates, and there is steel ball on the end for pushing the object. The motor is a normal PM stepping motor and can be driven with a standard stepping motor driver. The characteristics assume intermittent driving. Power consumption during continuous operation is about 1 W (without heat sink), 5 W (B5 1 mm steel plate attached).

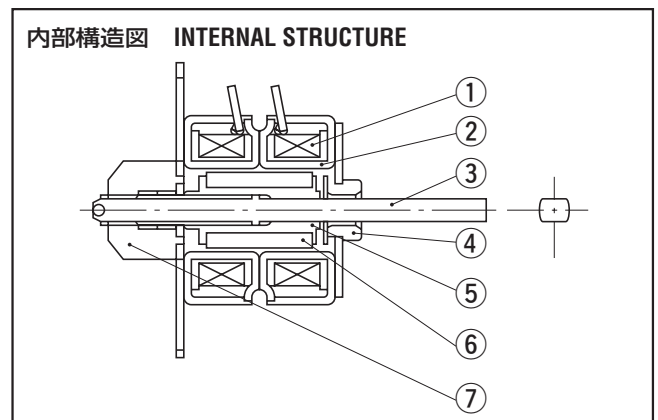
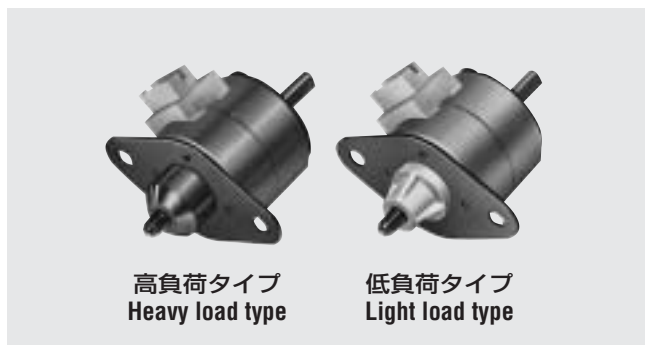

■特長 FEATURES

- 精密位置制御が可能 (25 μm/step、±7 μm：初期値)
- 小型・高推力
- 自己保持機能内蔵：電源offで位置保持ができます
- ソフトランニングが可能
- 比例制御が簡単にできます

- Precision position control is possible (25 μm/step, ±7 μm: initial value)
- Compact, high thrust
- Internal self holding function: Position can be held with power off
- Soft running is possible
- Proportional control is easy

Part name	
①	ステータコイル / Stator coil
②	ステータ鉄心 / Stator core
③	シャフト / Shaft
④	後部軸受 / Rear bearing
⑤	ロータ / Rotor
⑥	ロータマグネット / Rotor magnet
⑦	前部軸受 / Front bearing

■用途 APPLICATIONS

●レバー操作 Lever operation

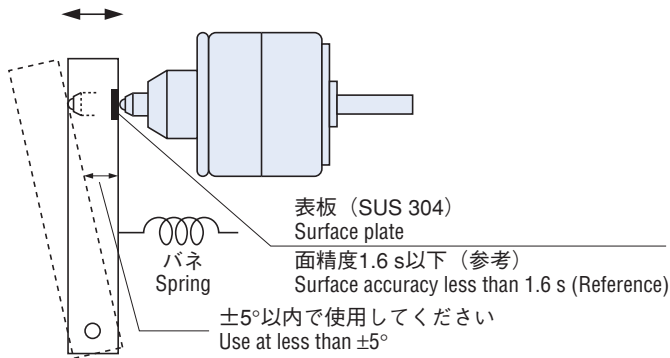

●流量制御 Flow control

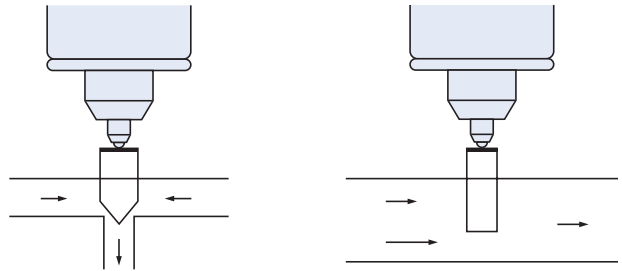

●精密位置制御 Precision positioning control

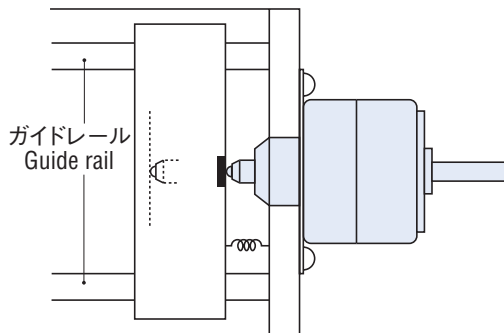

●孔の開閉 Opening and closing hole

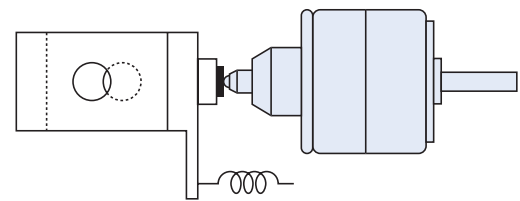

●その他 Others

- プリンタリボンのup/down
- X-Yテーブルの微動
- エアコンの吹出し調整など

- Printer ribbon up/down
- Minute movement of X-Y table
- Airconditioner regulation

●ポンプ Pump

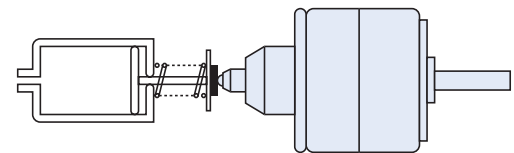

■型式表示 PART NUMBER DESIGNATION

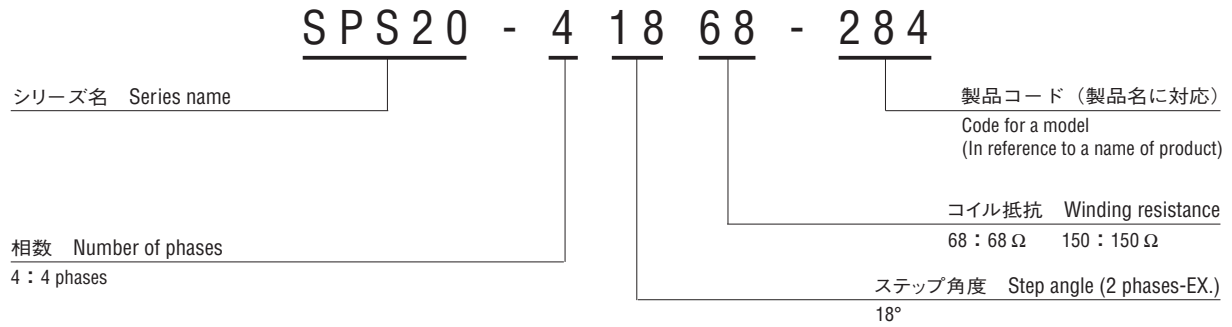

■型式一覧表 LIST OF PART NUMBERS

シリーズ Series	コイル抵抗 Winding resistance	
	68 Ω	150 Ω
高負荷タイプ	SPS20-41868-285	SPS20-418150-288
低負荷タイプ	SPS20-41868-284	SPS20-418150-287

※ ご注文際には、上記型式をご確認ください。
Verify the above part numbers when placing orders.

■外形寸法図 OUTLINE DIMENSIONS

(Unit: mm)

SPS20共通 Outline dimensions are common in SPS20 series.

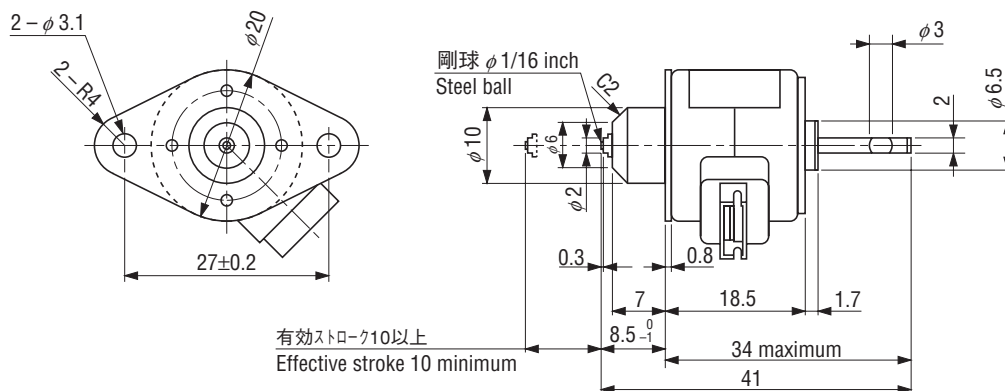

SPS20 STEPPING MOTORS

■特性図 (参考値) PERFORMANCE CURVES (Reference values)

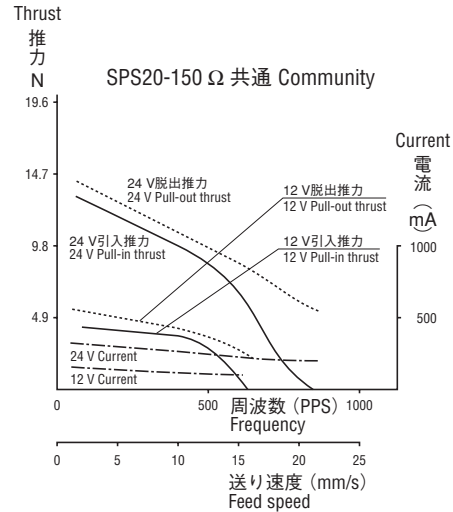
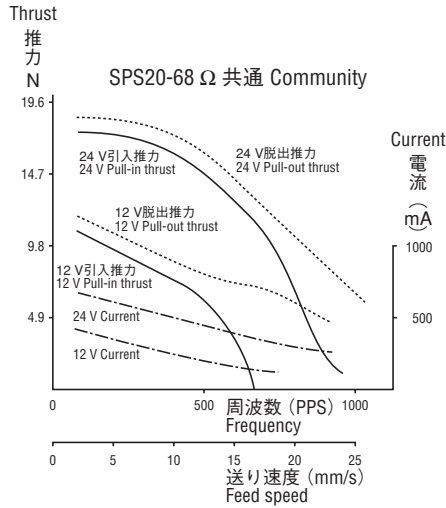

※特性は実測値です。保証値ではありません。
These performance curves show actual value, not guaranteed value.

■温度特性 TEMPERATURE CHARACTERISTICS

(at 500 pps-2 phases-EX., Heat sink 180 mm × 255 mm × 1 mm steel plate)

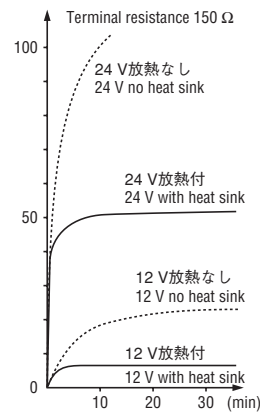
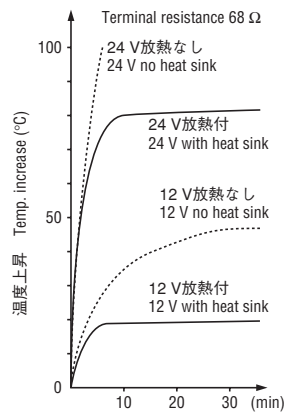

■標準仕様 STANDARD SPECIFICATIONS

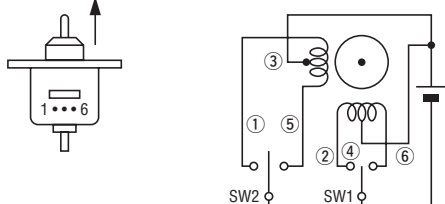
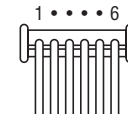
項目 Item	SPS20				備考 Remarks																																		
	41868-285	418150-288	41868-284	418150-287																																			
相数 Number of phases	4相ユニポーラ 4 phases unipolar				—																																		
1回転ステップ数 Steps	20				2 phases-EX.																																		
スクルーピッチ Screw pitch	0.5 mm				—																																		
ステップサイズ Step size	25 μm				2 phases-EX.																																		
コイル抵抗 Winding resistance	68 Ω	150 Ω	68 Ω	150 Ω	—																																		
許容スラスト荷重 Allowable thrust	49 N		9.8 N																																				
推力 Thrust	7.85 N		2.94 N		参考値 Reference value																																		
電圧 Voltage	特性図参照 Refer to PERFORMANCE CURVES				初期実力値 Initial strength value																																		
電流 Current																																							
引入推力 Pull-in thrust																																							
脱出推力 Pull-out thrust																																							
温度上昇 Temperature increase	温度特性表参照 Refer to TEMPERATURE CHARACTERISTICS				—																																		
絶縁抵抗 Insulation resistance	30 MΩ minimum				DC500 V																																		
絶縁耐力 Dielectric strength	500 Vrms				AC, 1 min																																		
機械的ストローク Effective mechanical stroke	12 mm				—																																		
有効ストローク Effective stroke	10 mm																																						
使用温度範囲 Operating temperature range	0 ~ 50 °C				—																																		
保存温度範囲 Storage temperature range	-30 ~ 60 °C																																						
寿命 Life	100万サイクル 1 million cycles		80万サイクル 800 thousand cycles		参考値 Reference value ※1																																		
	7.4 Nにて at a load of 7.4 N		2.5 Nにて at a load of 2.5 N																																				
質量 Net weight	Approx. 45 g				—																																		
結線図 Wiring diagram	 <p>1→4の時、シャフト前進(矢印) When excitation is in order the motor shaft moves ahead.</p> <table border="1" data-bbox="909 1747 1212 1960"> <thead> <tr> <th></th> <th colspan="2">SW1</th> <th colspan="2">SW2</th> </tr> <tr> <th></th> <th>⑥</th> <th>②</th> <th>⑤</th> <th>①</th> </tr> </thead> <tbody> <tr> <td>1</td> <td>ON</td> <td></td> <td>ON</td> <td></td> </tr> <tr> <td>2</td> <td></td> <td>ON</td> <td>ON</td> <td></td> </tr> <tr> <td>3</td> <td></td> <td>ON</td> <td></td> <td>ON</td> </tr> <tr> <td>4</td> <td>ON</td> <td></td> <td></td> <td>ON</td> </tr> <tr> <td>1</td> <td>ON</td> <td></td> <td>ON</td> <td></td> </tr> </tbody> </table> <p>専用コネクタ 日本圧着端子製造 06ZR-8Mまたは、ZHR-6 Connector Made by J.S.T.</p> 					SW1		SW2			⑥	②	⑤	①	1	ON		ON		2		ON	ON		3		ON		ON	4	ON			ON	1	ON		ON	
	SW1		SW2																																				
	⑥	②	⑤	①																																			
1	ON		ON																																				
2		ON	ON																																				
3		ON		ON																																			
4	ON			ON																																			
1	ON		ON																																				

※1：寿命は使用条件により大幅に変わります。別途お問い合わせください。
Life depends on greatly how to use it. For more information, please contact us.